

# Scotia LED Floodlight Luminaire

## ATEX, IECEx and UKEX

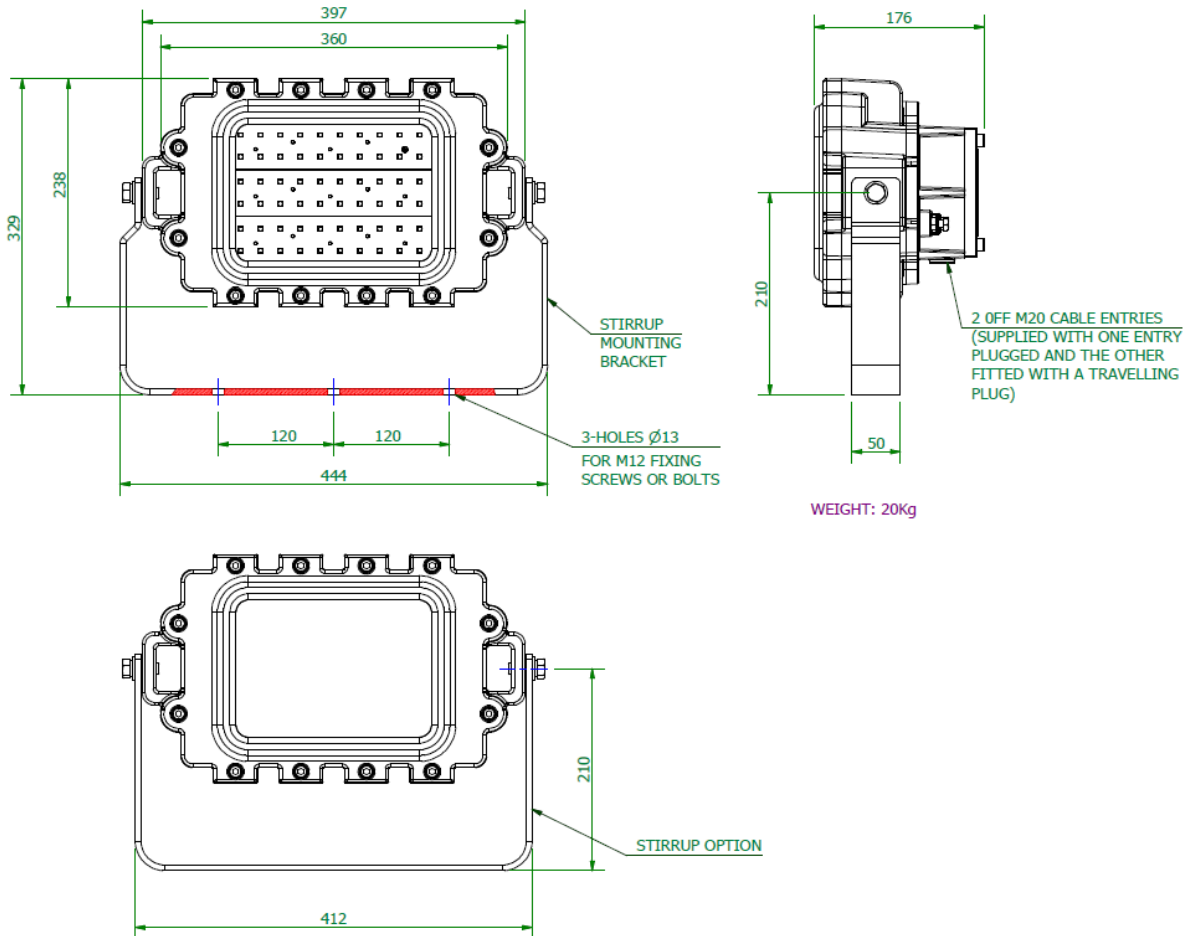

### INSTALLATION, OPERATION AND MAINTENANCE INSTRUCTIONS

**Important:** Please read these instructions carefully before installing or maintaining this equipment. Good electrical practices should be followed at all times and this data should be used as a guide only.





Specification

Type of Protection	Ex de (flameproof and increased safety), Ex tb (dust)
Protection Standards	EN/IEC 60079-0, EN/IEC 60079-1, EN/IEC 60079-7, EN/IEC 60079-31
Area Classification	Zone 1 and Zone 2 areas to (IEC) EN60079-10-1 Zone 21 and Zone 22 areas to (IEC) EN60079-10-2
Installation	(IEC) EN 60079-14
Certificate	IECEX Certificate of Conformity IECEx CML14.0034X EU Type Examination Certificate CML14ATEX1086X UK Type Examination Certificate CML21UKEX1502X
Equipment Coding	Ex db eb IIB T* Gb -50°C ≤ Ta ≤ *°C or Ex db eb IIB + H2 T* Gb -20°C ≤ Ta ≤ *°C Ex tb IIIC T**°C Db IP6X (Refer to Table 1 for temperature rating)
ATEX/UKEX Coding	⊕ II 2 GD
Ingress Protection	IP66
Photobiological safety of Lamps and Lamp Systems	Risk Group 2 LED product to IEC 62471. Avoid looking at exposed LEDs in operation especially with optical instruments. Eye injury can result.
<b>WARNING! DO NOT OPEN WHEN AN EXPLOSIVE ATMOSPHERE IS PRESENT</b>	
  	<p>The CE marking of this product applies to "The Electrical Equipment (Safety) Directive", "The Electromagnetic Compatibility Directive", the "Waste Electrical and Electronic Equipment Directive" and the "Equipment and Protective Systems intended for use in Explosive Atmospheres Directive". [2014/35/EU, 2014/30/EU, 2012/19/EU and 2014/34/EU respectively].</p> <p>The UKCA marking of this product applies to "The Electrical Equipment (Safety) Regulations 2016", "The Electromagnetic Compatibility Regulations 2016", the "Waste Electrical and Electronic Equipment Regulations 2012" and the "Equipment and Protective Systems intended for use in Explosive Atmospheres Regulations 2016</p> <p>The Equipment is declared to meet the provisions of the ATEX directive (2014/34/EU) by reason of the Type Examination/EU Type Examination and meets the UK statutory requirements SI 2016 No.1107 and compliance with the Essential Health and Safety Requirements. M Poutney Technical Manager</p>

**SPECIAL CONDITIONS FOR SAFE USE**

1. In accordance with clause 5.1 of EN 60079-1, the critical dimensions of all non-threaded flamepaths are: 9.5mm minimum in length with a 0.05mm max gap.
2. Leads connected to the terminals shall be insulated for the appropriate voltage and this insulation shall extend to within 1 mm of the metal of the terminal throat.
3. All terminal screws, used and unused, shall be tightened down to between 1.2 Nm and 2 Nm.
4. Shall only be installed and wired with cable in an ambient temperature of -10°C to +80°C.

**1.0 Introduction – SCOTIA FLOODLIGHT**

The Scotia LED Floodlight Luminaire operates from mains voltage.

**Table 1 MODEL VARIATIONS**

POWER FACTOR >0.95      Power is constant over voltage range



CHALMIT MODEL NUMBER	WATTS	Hz	VOLTS	AMPS	T* CLASS AT 40°C	T* CLASS AT 55°C	SURFACE T** AT 40°C	SURFACE T* * AT 55°C
SCOD/12L/LE/**/**	132	50/60	120-277	1.12 - 0.48	T6	T5	T85	T100
SCOD/11L/LE/**/**	106	50/60	120-277	0.91 - 0.4	T6	T5	T85	T100
SCOD/08L/LE/**/**	99	50/60	120-277	0.85 - 0.37	T6	T5	T85	T100
SCOD/07L/LE/**/**	78	50/60	120-277	0.67 - 0.29	T6	T5	T85	T100

OPTIONS - SUFFIX TO CATALOGUE NO.

/LT - LOW TEMPERATURE VERSION

/M25 - M25 ENTRIES

/H2 - H2 GAS

/304 - STRAIGHT STIRRUP MOUNTING BRACKET

## 2.0 Storage

Luminaire and led driver are to be stored in cool dry conditions preventing ingress of moisture and condensation.

## 3.0 Installation and Safety

### 3.1 General

There is no health hazards associated with this product whilst in normal use. However, care should be exercised during the following operations. Installation should be carried out in accordance with *EN/IEC 60079-14* or the local hazardous area code of practice, whichever is appropriate, and fitting of specified insulating material to be adhered to where a specific fire resistance rating is required.

In the UK the requirements of the '*Health and Safety at Work Act*' must be met.

Handling and electrical work associated with this product to be in accordance with the '*Manual Handling Operations Regulations*' and '*Electricity at Work Regulations, 1989*'. Your attention is drawn to the paragraphs

- (i) 'Electrical Supplies',
- (ii) 'Electrical Fault Finding and Replacement' and
- (iii) 'Inspection and Maintenance'. The luminaires are Class 1 and should be effectively earthed.

The luminaires are quite heavy and suitable means of handling on installation must be provided.

Maximum Insulation Resistance Test 500V dc.

Guards and External Reflector can be supplied with or fitted retrospectively, the guard is to protect glass if there is a higher than normal risk of mechanical damage. The guard and External Reflector cannot be fitted together.

This LED Floodlight luminaire has passed thermal shock testing during certification, it is still advisable to mount the Floodlight in locations to reduce the possibility of thermal shock.

Certification details on the rating plate must be verified against the application requirements before installation.

The information in this leaflet is correct at the time of publication. The company reserves the right to make specification changes as required.

### 3.1.1 Use in Combustible Dust Atmospheres

Where the equipment is used in ignitable dust atmospheres reference must be made to the selection and installation standards in order that the equipment is used correctly. In particular this applies to the de-rating of surface temperature for use where dust clouds may be present. Dust layers should not be allowed to accumulate on the fitting surface and good housekeeping is required for safe operation. Dust in layers has the potential to form ignitable clouds and to burn at lower temperatures. Refer to *EN/IEC 60079-10-2* & *EN/IEC 60079-14* for additional details of selection and installation.

### 3.1.2 Hybrid Mixtures – Gas plus Dust.

Where Hybrid mixtures exist as defined in *EN1127* as a potentially explosive atmosphere, consideration should be given to verifying that the maximum surface temperature of the luminaire is below the ignition temperature of the hybrid mixture.

### 3.1.3 Floodlight Orientation in the presence of combustible dust.

The luminaire was tested in accordance with *EN/IEC 60079-31*. As the build up of the dust layer can never be guaranteed not to occur, the luminaire must not be mounted in an orientation where the dust could lie on the glass. The temperature on the



glass is the hottest point on the luminaire and any obstruction of the radiation from the luminaire would cause the surface temperature to increase.

### 3.2 Tools

6mm A/F socket keys  
4mm flat blade screwdriver  
Suitable spanners for installing cable glands  
Pliers, knife, wire strippers/cutters

### 3.3 Electrical Supplies

A maximum voltage variation of +6%/-6% on the nominal is expected. The safety limit for T rating is +10%.

### 3.4 Light Source

The luminaire is fitted with LEDS that can last 80,000 hours depending on ambient temperatures. Therefore depending on the functionality of the fitting replacement of LED's will be rare /unnecessary. If the LED assembly needs replaced refer to **4.2 LED Replacement**.

### 3.5 Mounting

Luminaires should be installed where access for maintenance is practical and in accordance with any lighting design information provided for the installation. This will usually consist of aiming points and aiming angles. Mounting arrangements should be secured with lock washers or self-locking nuts and bolts.

### 3.6 Cabling and Cable Glands

#### 3.6.1 Cable Glands

The installer and user must take responsibility for the selection of cables, cable glands and seals.

The product is certified for ATEX, IECEx and UKEX and to comply with the certification for installation cable glands and sealing plugs must be ATEX, IECEx or UKEX certified depending on site requirements.

Cable glands for entry into Ex e enclosures when fitted with any gland to body sealing method and the supply cable must reliably maintain the IP rating of the enclosure IP66.

The cable gland must withstand an impact value of 7Nm where the risk of mechanical damage is high or 4Nm where the risk of mechanical damage is low.

Sealing plugs must be similarly rated and a tool must be used for their removal. Where the cable is not reliably clamped externally to the apparatus, the cable gland must clamp the cable against a pull in Newtons of 20x the cable OD in mm for non-armoured cable and 80x the cable OD for armoured cable. Where brass cable glands are used in a corrosive environment cadmium or nickel plating should be used. Two tapped cable entries are provided, one with a plug and seal suitable for permanent use, the other has a travelling plug. M20 x 1.5 entries are standard, other sizes are available on request up to M25 x 1.5p.

#### 3.6.2 Cable

The temperature ratings of the entries at 55°C ambient requires cable rated at 90°C. Cables rated at 35°C above ambient are suitable for use at lower ambient installations.

#### 3.6.3 Cable Connection

The cable connections are made by removing the terminal chamber cover. The retaining screws are captive and should be re-greased as required. The conductors should be bared back so that they make full contact in the terminals, but the bare conductor should not be more than 1mm beyond the terminal. Unused terminal screws should be tightened. The core must be identified by polarity and connected in accordance with the terminal markings. Before re-fitting the cover, a final check on the correctness of connections should be made. Terminal chamber cover bolt torque 6 Nm.

### 4.0 Inspection and Maintenance

Individual organisations will have their own procedures for inspection and maintenance. What follows are guidelines based on *EN/IEC 60079-17* and on our experience. Maintenance work and fault finding must be performed by competent personnel under an appropriate permit to work and with the apparatus isolated. Frequency of maintenance will depend on experience and the operating conditions.

**Luminaire should not be opened when an explosive atmosphere is present.**

Maximum Insulation Resistance Test 500V dc.



- 1 Check if any LED's have failed (do not light).
- 2 The LEDs are mounted on boards, if there is 3 or more LED's not working on one board the light output will have dropped to a level where the LED board may need replaced. Refer to **4.2 LED Replacement**.
- 3 Check the terminal chamber bolts for tightness.
- 4 Check the cable gland for tightness and re-tighten if necessary.
- 5 Check any external earthing.
- 6 Examine the LED glass for any signs of damage and for any signs of sealant damage, cracking or discoloration. If thought necessary, the silicone weather seal can be re-sealed with a proprietary brand of clear RTV silicone, but only if the underlying sealant is in good condition.
- 7 Check all cover bolts for tightness. Torque 16Nm
- 8 Check for signs of corrosion between the LED glass cover and the main housing. Evaluation of this will be a matter for judgement gained by experience, as there may be little evidence on the outside. If there is any sign of corrosion, remove the cover and wipe the flameproof paths with a clean cloth and non-metallic scraper. Examine the surfaces for pitting; any pitted component should be replaced. A damaged or non-resilient gasket must be replaced (supplied by Chalmit).

The cover should be re-fitted with all bolts fully tightened. Any replacement bolts must be identical to the original. All are 18/8 stainless steel with a minimum of ISO262 Grade A4-70.

With this type of flameproof path all bolts must be in place and tight. The maximum gap for IIB + H2 in this case is 0.05mm. It would be unusual for any of our luminaires to have a gap exceeding 0.05mm when tried with a feeler gauge. If 0.05mm is exceeded check that no foreign bodies or debris at the bottom of blank tapped holes are keeping the surfaces apart and if not, a workshop overhaul should be carried out to bring the unit into new condition. Even if there are no signs of external corrosion the front cover should be removed at a minimum of every 3 years and the internal connections checked for tightness and any signs of overheating.
- 9 The terminal chamber should be opened periodically and checked for moisture and dirt ingress. The cable connections should be checked for tightness. The gasket should be checked for cracks or lack of elasticity, and if necessary, replaced. (It may well be practical to also replace the gasket on each occasion if this is at a 3-year interval). (supplied by Chalmit).
- 10 If painting operations have taken place around the luminaire, ensure that coatings have not entered the flameproof path or been deposited on the LED glass. If they have, dismantle and clean carefully.
- 11 Check that mountings are secure.
- 12 Cover the bolt heads with silicone grease to prevent corrosion and accumulation of dirt in the screw threads.
- 13 Clean the LED glass.
- 14 If there is suspicion that the luminaire has suffered mechanical damage, a stringent workshop check should be made.

**Important:** *Where spares are needed, these must be replaced with manufacturer parts. No modifications should be made without the knowledge and approval of the manufacturer.*

#### 4.1 Electrical Fault Finding and Replacement

Any fault finding must be done by a competent electrician with the luminaire isolated and if carried out with the luminaire in place, under a permit to work. Fault finding is by substitution with known good components.

#### 4.2 LED Replacement.

The need and frequency of replacing LED's be dependent on the functionality of the fitting. If it is continually running at high ambient temperatures it will affect the frequency of LED replacement. If it is necessary to replace the LED's, the LED's are mounted on boards that can be replaced individually. (The boards with LED's supplied by Chalmit ).

Removal of LED assembly is as follows:

1. Unscrew 5 off screws that secure the board to the casting.
2. Carefully lift the plate and disconnect push in connector.

Replacement of LED assembly is the reverse of the removal.  
Replace Front cover and fully tighten all bolts.

### 5.0 Disposal of Material

The unit is mostly made from incombustible materials. The control gear contains electronic components and synthetic resin. All these may give off noxious fumes if incinerated. Care must be taken to render these fumes harmless and avoid inhalation. Any local regulations concerning disposal must be complied with. Any disposal must satisfy the requirements of the WEEE directive [2012/19/EU and Regulations 2012] and therefore must not be treated as commercial waste.



To comply with the Waste Electrical and Electronic Equipment directive 2012/19/EU and Regulations 2012 the apparatus cannot be classified as commercial waste and as such must be disposed of or recycled in such a manner as to reduce the environmental impact.

**Directions for Installation of Accessories**

Note: Reflector and Guard cannot be used simultaneously

**WARNING:** Ensure the supply circuit is off before starting installation.

To install reflector, verify that the luminaire is completely assembled. Install lens reflector on lens assembly by first hooking the top of the reflector over the top of the luminaire, lining up the holes in the reflector with the holes on the lens housing. Next, manoeuvre the mounting legs on the bottom of the reflector around the base of the luminaire, verifying that the legs align into proper position. Finally, install the (2) M8 mounting screws in the back of the reflector to secure the reflector to the luminaire housing.

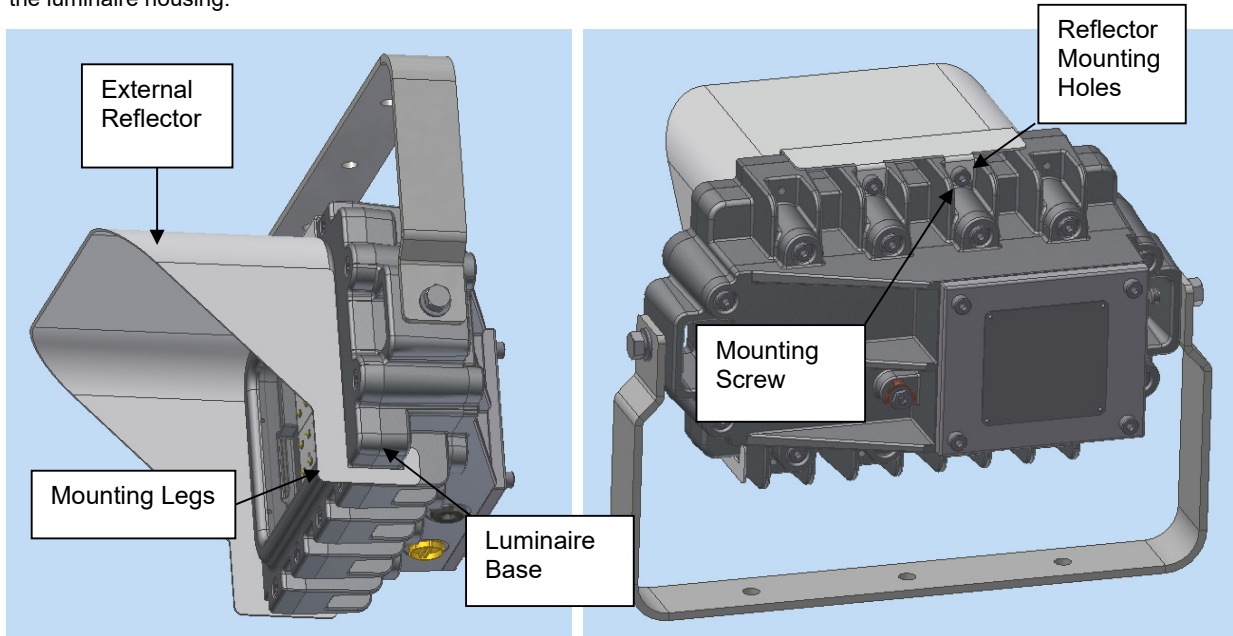

To install lens assembly guard (KF1LG), verify that the luminaire is completely assembled. Install lens guard on lens assembly by hooking the guard's spring-action end tabs around the luminaire housing's end tabs. Verify a tight attachment.

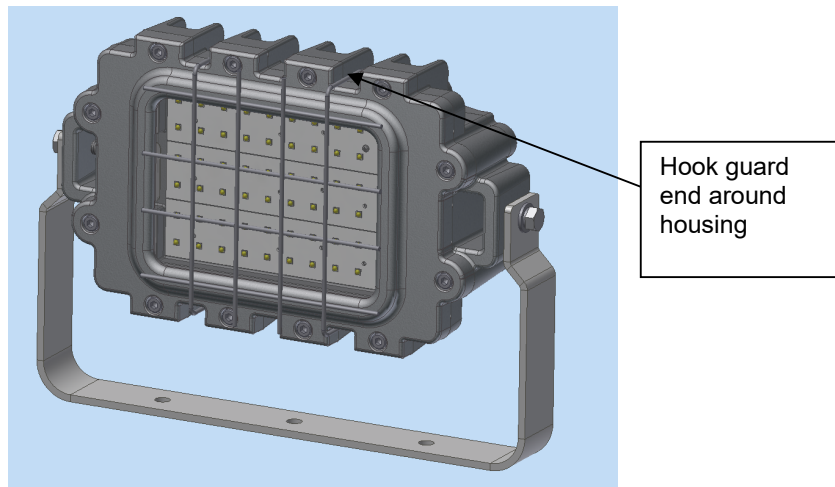



	<b>EU/UK-Declaration of conformity</b>		
	<b>UE-Déclaration de conformité</b>		
	<b>EU-Konformitätserklärung</b>		
Manufacturer	Chalmit	Address	388 Hillington Road, Glasgow. G52 4BL Scotland UK
Product	Scotia LED Luminaire		
Notified Body	CML B.V. 2776		
EU Type Examination Certificate	CML 14ATEX1086X		
Approved Body	Eurofins CML 2503		
UK Type Examination Certificate	CML 21UKEX1502X		
ATEX/UKEX Coding	II 2 GD		
ATEX/UKEX Classification	Group II Category 2 GD		
Equipment Coding	Ex db eb IIB T* Gb -50°C ≤ Ta ≤ **°C or Ex db eb IIB + H2 T* Gb -20°C ≤ Ta ≤ **°C Ex tb IIIC T**°C Db IP6X		
Ingress Protection	IP66		
The technical basis, with respect to equivalence of			
La base technique, en ce qui concerne l'équivalence de			
Die technische Grundlage hinsichtlich der Normen			
Protection Standards EN 60079-0, EN 60079-1, EN 60079-7, EN 60079-31.			
Area Classification EN 60079-10-1 and EN 60079-10-2			
of compliance with the EHSRs is valid as there are no changes which materially affect the state of technological progress of the product.			
en conformité avec les EESS est valide puisqu'il n'y a aucun changement qui affecte matériellement l'état de l'évolution technologique du produit.			
zur Erfüllung der GSGA ist gegeben, da keine Änderungen erfolgt sind, die einen Einfluss auf den technischen Stand des Produkts haben.			
Terms of the directive:		Standard & Date Certified to	Standards Date Declared to
Prescription de la directive:		Standard & date certifiée à	Normes date Déclaré
Bestimmungen der Richtlinie:		Standard & Datum Zertifiziert nach	Standards Datum erklärt
2014/34/EU SI 2016 No.1107	Equipment and protective systems intended for use in potentially explosive atmospheres.	EN 60079-0: 2012 EN 60079-1: 2014	
2014/34/UE	Appareils et les systèmes de protection destinés à être utilisés en atmosphères potentiellement explosibles.	EN 60079-7: 2015 EN 60079-31: 2014	
2014/34/EU	Geräte und Schutzsysteme zur bestimmungsgemäßen Verwendung in explosionsfähigen Bereichen.		
2014/30/EU Regulations 2016	Electromagnetic compatibility	EN 55015 : 2019	
2014/30/UE	Compatibilité électromagnétique	EN 61547 : 2009	
2014/30/EU	Elektromagnetische Verträglichkeit	EN 61000-3-2 : 2019	
2014/35/EU Regulations 2016	Low voltage equipment	EN 60598-1 : 2015	
2014/35/UE	Équipements électriques à bas voltage	EN 60598-2-5 : 2015	
2014/35/EU	Niederspannungsgeräte / -systeme	EN 60529 : 1992+A2:2013	
2012/19/EU Regulations 2012	Waste of electrical and electronic equipment		





IOM – SCOTIA - ZONE 1 LED FLOODLIGHT (ATEX, IECEx and UKEX)

2012/19/UE	Déchets d'équipements électriques et électroniques		
2012/19/EU	Entsorgung der elektrischen und elektronischen Geräte / Systeme		
2011/65/EU Regulations 2012	RoHS II Directive		

On behalf of the Chalmit, I declare that, on the date the equipment accompanied by this declaration is placed on the market, the equipment conforms to all technical and regulatory requirements of the above listed directives.

En tant que représentant du fabricant Chalmit, je déclare qu'à la date où les équipements accompagnant cette déclaration sont mis sur le marché, ceux-ci sont conformes à toutes les dispositions réglementaires et techniques des directives énumérées ci-dessus.

Hiermit bestätige ich, im Namen von Chalmit, dass am Tag der Lieferung des Produkts/der Produkte zusammen mit dieser Erklärung das Gerät/die Geräte alle technischen und regulativen Anforderungen der oben aufgeführten Direktiven erfüllt.

Name and Date Mark Poutney 10/11/2021  
Nom et Date  
Name und Datum

Technical Manager  
Directeur technique  
Technischer Leiter

Quality Assurance Notification by:  
Notification d'assurance qualité par:  
Qualitätssicherungsnotifikation durch:

**SGS Fimko OY**  
**0598**

Quality Management System Accreditation:  
Système de Management Qualité Accréditation:  
Qualitätsmanagementsystem Akkreditierung:  
Environmental Management System.  
Système de gestion de l'environnement.  
Umwelt kontroll system.

**ISO 9001**

**ISO 14001**  
by/par/durch  
**Lloyd's Register**  
**LRQ 4005876**

UKCA Quality Assurance Notification  
by:

**SGS Fimko OY**  
**0598**

**Certificate No./Certificat N°/Zertifikat Nr.**